

## GENERAL RULES

**\*THE INTENT AND INTERPRETATION OF THE RULES WILL BE THE DECISION OF OFFICIALS IN CHARGE. IT IS STRONGLY RECOMMENDED THAT ANY COMPETITOR THAT HAS ANY QUESTIONS OR DOUBT ABOUT THE INTERPRETATION OR INTENT OF THE RULES CHECK WITH SPEEDWAY OFFICIALS. ALL DECISIONS OF THE OFFICIAL IN CHARGE SHALL BE FINAL.**

Unless otherwise stated in a particular division, **these general rules apply to all divisions.**

## SAFETY

**NOTE: The following safety rules set forth by the SPEEDWAY do not guarantee prevention of personal injury, but are a guideline to building a safer racing vehicle.**

- A. Fuel cells are required. The maximum capacity allowed is 22 gallons. Fuel cell must have a working check valve and foam.
- B. Fuel cell must be mounted equal distance between rear frame rails and at least 8" above ground.
- C. Fuel cell vent and overflow may not exceed 1" in diameter. Overflow must exit at rear of car.
- D. Fuel cell must have four (4) 1/8" x 1" straps under cell and at least two (2) on top of cell bolted to fuel cell frame.
- E. Fuel cell must be protected at rear by 1-1/2" roll bar tubing extending below rear of frame 1/2" beyond bottom of cell and the width of the cell, with one (1) center brace.
- F. Fuel line must be run in metal tubing or metal conduit from cell to pump.  
No electric fuel pumps permitted.
- G. Cars must have fire extinguisher on-board in working order with gauge.  
Must be in driver's reach. Driver responsible for updating.
- H. Drive Shaft and Bolt on Lead or Ballast must be painted white.
- I. Window Net required. Must release from top and mount on roll cage at bottom.
- J. Steering Wheel must be padded at center. Release hub recommended.
- K. All Roll Bars in driver's reach must be padded.
- L. No open holes in floor pan or firewalls permitted.
- M. **Five (5) Point Harness System with 3" lap belt and shoulder harness required.**
  - 1. Both ends must be fastened to roll bar cage of car with aircraft quality bolts, no less than 3/8" in diameter.
  - 2. A steel plate may be welded to roll bar cage on right side of driver so that the belt can be brought down in such a manner that it will keep the driver from sliding from side to side under the belt.
  - 3. The belt must come from behind the driver over roll bar.
- N. At least two (2) return springs required on throttle.
- O. Switches must be within driver's reach with belts on.
- P. Helmets are required and should meet Federal Motor Vehicle

Safety Standards.

- Q. All drivers are required to wear approved flame retardant suits and gloves during all practice, qualifying and race conditions. (NO Coveralls)**
- R.** Radiator overflow must be run up to windshield so driver or official can see water in case car runs hot.
- S.** Absolutely **NO ANTIFREEZE** in coolant system.

### **ROLL CAGE**

1. Steel Roll bars must be 1 1/2" outside diameter minimum.
2. Four (4) bars are required on driver's side extending from main cage to door, three (3) bars on right side. All seams and joints must be welded solid.
3. Roll Cage must be approved by SPEEDWAY officials before entering race track.

### **SEATS**

1. Bucket seats are mandatory and must be approved. Seats may be fiberglass or aluminum, bolted to seat frame attached to roll cage.
2. Seat must be high back with padded head rest.
3. Location of seat cannot extend past rear of door.

### **APPEARANCE**

1. All cars must be neatly painted and maintained.
2. Numbers must be at least 24" on both right and left side of car. No Silver or Gold numbers. **TWO NUMBERS ONLY. NO LETTERS**
3. **NO duplicate numbers.** Numbers have to be assigned through the track. Duplicates will be reassigned at track discretion.  
For number Call: Sandra Parker 798-2171 or 999-3510.

### **PROTESTS**

- A.** Only drivers can appoint someone to inspect car or protest. Protesting driver must compete in feature race. No protesting anyone finishing behind you. All protest must receive approval of Chief Pit Steward. Spite protest or protest done in an unsportsmanlike manner will not be accepted. Protest must be made within 10 minutes of feature. You have 45 minutes to be ready to be teched.
- B.** Visual protest (requiring no measurements whatsoever) must be presented to Chief Pit Steward in writing **BEFORE THE DRIVERS MEETING** starts. \$30.00 non refundable charge.  
**NO VISUAL PROTEST CAN BE MADE AFTER THE RACE IS OVER.**
- C.** All other protest or claims must be presented to Chief Pit Steward in writing within 10 minutes of finish of feature race accompanied by \$150.00 per protest; \$25.00 is given to the person designated to make measurements; and \$125.00 to the driver who wins the protest.
- D.** Driver of cars found illegal forfeit points, money earned and will start on rear the the next race they attend.
- E.** Any driver refusing to tear down will not be allowed to protest another driver for the remaining season.

## **ENFORCEMENT**

- A. The fact that an infraction is not noted does not make it legal
- B. Chief Pit Steward may add weight for infractions that create an advantage.
- C. The Chief Pit Steward has the final word on any rule or protest.
- D. All problems will be handled in a calm and sportsmanlike manner. Anyone not conducting themselves in a sportsmanlike manner may have their license revoked for an indefinite period of time.
- E. Loose lead found on any car after race will automatically disqualify car. **(NO Excuses)**
- F. Can be black flagged for dragging pieces. Will need to be checked for safety by pit official.
- G. If you spin someone out, **BOTH** cars will be sent to rear.
- H. **NO** 2 Way Radios will be allowed

## **CONDUCT IN PIT AREA**

- A. Drivers and/or car owners are responsible for their entire pit crew.
- B. **ABSOLUTELY NO DRINKING BY ANYONE WILL BE ALLOWED IN THE PIT AREA.**
- C. Any pit crew member or anyone else in the pit area who violates the above stated rule will be in contempt and be fined \$50.00. In addition, the driver will lose all winnings and points for the event, and will be suspended from the next racing event.
- D. Drivers and crew members will conduct themselves in a calm and sportsmanlike manner at all times. Any one throwing anything will be Fined & Barred. Minimum Fine \$100.
- E. Any crew member or fan in the pit area who uses loud and abusive language towards a pit crew member or track official, or any individual who is guilty of starting or **engaging in a fight will be fined a minimum of \$100.00.** In addition, the driver will lose all winnings and points for the event, and could be suspended from the next 2 (two) racing events. According to severity, suspension can be indefinite. Anyone hitting a track official will be fined \$200 and suspended. Family or fans coming out of stands will automatically cause driver to lose points and money for that night.

## **FUEL**

The only approved fuel for operation of any racing vehicle on the SPEEDWAY is racing gasoline. ALCOHOL OR NITROUS IS STRICTLY PROHIBITED. Violations subject to a fine of \$200.00.

**NOTE:** The SPEEDWAY reserves the right to modify/change rules during the season as deemed necessary for safety, fair competition, or any other reason that track officials feel may be appropriate.

GENERAL RULES Continued

**TRACK HAS THE RIGHT TO BAR ANYONE WE FEEL IS BEING DETRIMENTAL TOWARDS THE TRACK OR DRIVERS THROUGH SOCIAL MEDIA OR ANY OTHER MEANS.**

**ATTENTION ALL DRIVERS**

**NO PROFANITY ON CARS. NO SUGGESTIVE ART WORK ON CARS.**

Drivers **MUST** purchase a yearly membership pit license before you race.

Points will be awarded in each division you race in. Therefore you **MUST PURCHASE** a membership pit license for each division you race in.

**YOU CANNOT** race in 2 (two) divisions in the same night except for the Renegades. Anyone may run these divisions as long as you have a **MEMBERSHIP** for **EACH CLASS** you race in.

**YOU CANNOT** race in Buzz once you move up from this divisions.

Buzz is a beginner division.

Anyone wishing to move down to street stock must check with track official before you race. Driver moving down is at track discretion.

## 2020 OPEN WHEEL MODIFIED (TENTATIVE)

**THE INTENT AND INTERPRETATION OF THE RULES WILL BE THE DECISION OF OFFICIALS IN CHARGE. IT IS STRONGLY RECOMMENDED THAT ANY COMPETITOR THAT HAS ANY QUESTIONS OR DOUBT ABOUT THE INTERPRETATION OR INTENT OF THE RULES CHECK WITH SPEEDWAY OFFICIALS. ALL DECISIONS OF THE OFFICIAL IN CHARGE SHALL BE FINAL.**

### **GENERAL**

1. American made frames 105" wheel base minimum
2. Cars must weigh 2550, 1 pound per lap burn off
3. Rear of engine must be mounted 72 inches forward from center line of rear axle.  
Engine offset within 2" of center of crossmember.
4. 2 way radios will be allowed for safety reasons. Track reserves the right to take away from any driver using them for wrong reason

### **WEIGHT:**

2550 Minimum 58.0% Left side max for Steel Head Built engines.  
2600 Minimum 58.0% Left side max for Aluminum Head Built engines.  
**NO** titanium products, parts or components allowed on chassis or suspension.  
**NO** gun-drilled, tubular or hollow bolt or studs anywhere on car.

### **ENGINES**

**NO** aluminum blocks. No Dry Sump Systems.  
Aluminum heads must bolt 50 lbs. in front of bell housing.

### **CARBURETOR**

One 2 barrel or 4 barrel only.

### **FRAMES**

Must maintain 4" ground clearance at all times. Factory production complete full 1960 or newer parallel American passenger car frames only with a Minimum wheelbase 108". Frames may be cut in rear only at point not further than 36 inches from center of rear end housing. Frames may not be widened or narrowed. Must be full and complete both sides.

## **SUSPENSION AND STEERING.**

Front steering must be unaltered approved OEM and be in stock location, and must be replaceable by OEM appearing parts. Tie rod ends and adjustment sleeve may be replaced by a minimum .625-inch rod end and steel tube. Stock passenger car spindles or fabricated spindles must be steel. Bottom A-frames cannot be altered or moved. Front sway bar must be stock appearing and diameter of 1 3/8" maximum. Steering parts must be steel approved OEM and must remain within original bolt pattern for type of frame used. **NO** rack & pinion allowed. Coil over kits with minimum of 4.5" springs on rear only. **NO** bump stops, coil binding or chassis stops allowed, maximum 2 spring rubbers per spring and a minimum of 500 pound front spring rate. **NO** driver adjustments from cockpit except for brakes.

## **BRAKES**

Must be steel, approved OEM APPEARING calipers, and cannot be lightened. Steel vented rotors only, no scalloped rotors. Rotors cannot be lightened.

## **BODIES**

All body rules are at the discretion of tech official. Must be full size roof. (Must cover halo) Body sides must be straight front to back with a maximum length of 120" starting from back of engine, maximum width of 66" and body rake of 6" must be straight front to rear and flat. Asphalt type nose piece allowed no wider than 43 1/2 inches. Engine compartment must remain open. Passenger side of body must be no further forward than rear of engine. Right side "A" posts must be within 8" of right side of car or 50 lbs. penalty. Wing window not included in measurement. Interior wings, belly pans, double skinned roofs, fins, wings, vanes, vertical ledges, ramps or any other air directing devices are not allowed. 12" MAX length triangular enclosure at the 'A' pillar will be allowed. All cars are required to have side nerf bars mounted even with outside of tire. Must maintain 4" ground clearance at all times. Spoiler Max. 8" x 66" rear spoiler with maximum of 4 straight forward braces no longer than 16" Late model spoiler braces may be used front or rear of spoiler. Gurney flaps or curls are allowed but will be included in all measurements.

## IGNITION

MSD or Crane Ignition boxes allowed. **NO** traction Control. 7600 rev limiter required

## FUEL

Sunoco Racing Fuel **ONLY**. **NO** performance-enhancing fuel additives of any kind. OBERG Fuel Line Safety Valve # SV-0828 required.

## TIRES AND WHEELS

8" steel wheels only. American Race Tire KK-704 With Sayre and Huntsville Stamp.  
**SOAK RULE: NO** Soaking or altering of tires in any manner allowed. Drivers soaking or altering tires will forfeit all purse and points for event and all points for year.

## SAFETY

1. Fuel cell required. 22 gallon max. It must not be lower than rear housing.
2. Left side window net required.
3. Seat belt and shoulder harness required. All belts must be quick release types. Harness must be type that comes individually over both shoulders. Racing seat only. Seat must be bolted or welded to roll cage.
4. Two (2) drive shaft supports are required. **NO** carbon fiber drive shafts permitted. Drive shaft must be painted white.
5. Fire suits, Gloves, Approved Helmet required.
6. Roll Bar padding required within all areas of drivers reach
7. Must have minimum 2-pound fire extinguisher with a gauge and a quick release mounted securely in car within reach of driver while belted in car.
8. All weight (lead) must be mounted above frame/inside frame rail with a minimum of two (2) 1/2 inch bolts. All weights are to be painted white or florecent with the car # painted on each piece. Any driver that loses any lead from his/her car will be fined \$10.00 per pound payable prior to any further competition. This rule is in effect during race day or practice days.
9. **NO** Titanium. Lines to fuel pressure gauge must be steel braided type.
10. OBERG Fuel - Line Safety Valve #SV-0828 required.
11. TRACK OFFICIALS must approve all safety equipment.

## OPEN WHEEL MODIFIED BODY DIMENSIONS FOR 2020

- A. 20 "max 16" min. (ground to center of bumpers, front and rear)
- B. 6.5 min. (center to center)
- C. 52" max. 42" min.
- D. Hood 4" max. drop (sides). sealed off from driver's compartment and max. 3" rake.
- E. 42" max.
- F. 6" max.
- G. 4" min.
- H. 19" max., must be same on both sides.
- I. 112" max. 108" min.
- J. 27" max 22" min.
- K. 72" max. or not past back of block, right side. Left side may extend forward to cover foot box.
- L. 18" max. 12" min. opening, both sides.
- M. With level, must have between 1/2" and 2" clearance at rear of roof, 1/2" to 5" at front.
- N. 120" max. 106" min.
- O. 48" max. 34" min.
- P. Spoiler 5"
- Q. Interior slope is 6" max. front to rear and flat across. If flat at front half of interior you have used up 50 % of your 6" so from behind driver to rear you may only have 3". Top of interior must be flush with top of door and quarter panels. An optional escape hatch from driver to passenger door to provide 12" opening allowed.
- R. 38" max 28" min.
- S. Max. no wider than front frame horns. Min. 24"
- T. 66" max. 24" min. no narrower than radiator.
- U. 52" max . 44" min.
- V. 56" max. 41" min.
- W. Tires must be widest part of car.
- X. 66" max. 53" min.
- Y. All rear bumpers must be constructed of square or round tubing, no wider than five inches outside of rear frame rails and similar to drawing. If rear bumper is wider than five inches outside rear frame rails, it must be constructed in a loop design.



Shaded area reserved for sponsor decals. MUST DISPLAY ALL DECALS TO BE ELIGIBLE FOR ANY CONTINGENCY AWARDS OR POINT FUNDS.

(P) 5" Spoiler

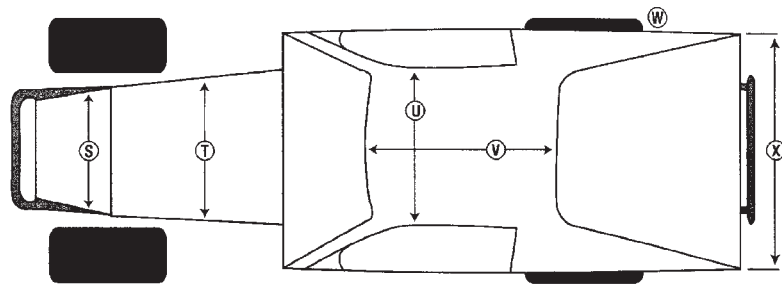
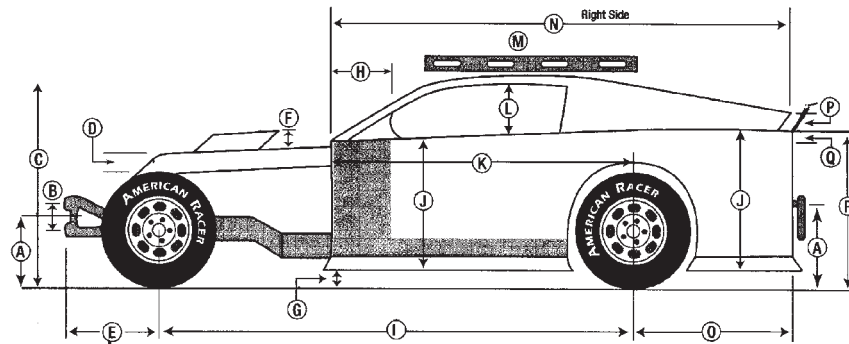

Sail Panel



Sail Panels

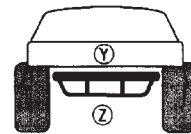
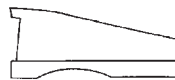

Rear Bumper

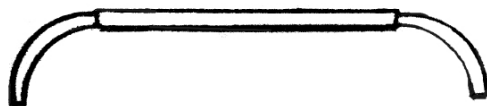

## 2020 BUZZ RULES {TENTATIVE}

### MOTOR RULES

Motor must have been available for make and model of auto claimed. Motor may be a newer version of motor for claimed auto but must be same "L" Liter. (Example: You may use a 3100 for a 3.1L. Another example: You have a 1994 Acura Integra with a B18C1 you may use a motor from a 2000 Honda Integra JDM B18C Type-R) ECM must still remain stock for year make and model.

**TRANSMISSION:** Transmission must have been available for make, model and year of auto "claimed". NO MIS-MATCH OF MOTOR & TRANSMISSION

NO aluminum flywheels

Plug wires: Optional 7mm or 8mm

Must run stock ignition coils-modules, chips, etc. (NO MSD)

**HP:** There is no limit on HP

Weight must be added for anything over 190 HP. Weight/HP ratio is 1lb/HP (Example: 205HP must add 15 lbs)

Weight must be mounted in the center of the passenger side where seat was previously mounted. For safety purposes must use grade 5 or stronger bolts with lock nuts to mount weight.

**REMEMBER:** If it doesn't say you can do it, you can't. Some things you will be able to call and get permission on to run. If this happens it is advisable for you to have this in writing and signed and dated from a Tech Official

4 cylinder - Automatic or Standard

6 cylinder - Automatic

American or Foreign stock cars Front Wheel Drive ONLY

**NO** high performance models

**NO** turbo or supercharged cars allowed.

**NO** NOS or other performance enhancing devices allowed

Door hinges, locks, and side impact bar must remain in door

Doors must be securely fastened shut

Must remove all glass

\*If using a glass windshiled must wear goggles or face shield

May use screen or lexan - must be completely across windshield area

May remove back seat, carpet, headliner, and trim panels

Must have mufflers on cars

## **WHEELS AND TIRES**

1. All 4 wheels must be same size 14" or 15" - 65 series
2. All wheels must be stock except right front may be 7" wide racing wheel. All other wheels must be no wider than 6".
3. **NO** leaning rear tires)
4. May run Max 2" spacer on right side to prevent tire scrub only

**SOAK RULE: NO** soaking or altering of tire in any manner allowed. Drivers soaking or altering tires will forfeit all purse and points for event and all points for year.

## **ROLL CAGE**

Four (4) point roll cage **MANDATORY**

## **SEAT**

Racing seat

Seatbelt - 5 point harness

Must cover all holes in front and rear firewall and floorboard.

## **FUEL CELL OR GAS TANK**

Fuel Cell must be centered in rear of the car no lower than the frame

May run Road Warrior cars combined with Buzz if car count is not enough

Track has right to change rules to make competition more equal.



## 2020 STREET STOCK (TENTATIVE)

THE INTENT AND INTERPRETATION OF THE RULES WILL BE THE DECISION OF OFFICIALS IN CHARGE. IT IS STRONGLY RECOMMENDED THAT ANY COMPETITOR THAT HAS ANY QUESTIONS OR DOUBT ABOUT THE INTERPRETATION OR INTENT OF THE RULES CHECK WITH SPEEDWAY OFFICIALS. ALL DECISIONS OF THE OFFICIAL IN CHARGE SHALL BE FINAL.

1. Anything not specified in Rules must be stock, in original position, from original manufacturer.
2. American made cars from 106" to 114" wheel base. **NO** Camaros or Mustangs. May run T-Bird
3. Cars must weigh minimum of 3100 lbs. with driver after race. 56% left side weight max. Weight may be added for minor infractions.
4. 360 cubic inch - NO 400 small blocks.
5. 602 Crate Engine will be allowed. Must run by GM spec.
6. **WEIGHT MAY BE ADDED TO MAKE COMPETITION EQUAL**

### ENGINE & DRIVE TRAIN

1. No engine larger than 350 CI .060 over OEM blocks only. Must have casting numbers on block.
2. CRANKSHAFT: Stock stroke, cast eagle or scat cranks OK (NO stroker cranks.)
3. RODS Must be stock appearing such as Eagle (SIR) or the Scat Rods
4. PISTONS: Flat-top pistons only (No Dome pistons)
5. CAM SHAFT: Hydraulic camshafts only. No Roller Cams. 3/8 studs in all heads. NO roller rockers (NO roller tip rockers. May run stamped steel rocker arms
6. INTAKE: Stock aluminum intake. May have center cut out for 2 barrel carburetor  
Chevys can run 2101 (NO altering)  
Vortec head can run 2716 (NO altering)  
Ford can run 2750 or 2181 (NO altering)  
Any other intake run will have a 100 lb penalty  
NO grinding or porting of intake
7. **HEADS: May run double hump, Vortec, 305 heads with 1.940, 1.500 valves. 62cc min. on Double Hump and Vortec heads. 100 lbs penalty on Vortec and double hump and 305 heads. Fords can run the GT40 heads with 100 lbs. penalty with stock size valves.**  
**Stock size valve springs only. Other heads that can be run casting # will have to be on heads. Numbers for Chevy 350 are**  
**(39863336) (333882) (462624)(3973487)(3998993)(3973493) (3932441)**  
**(932441) 1.940 1.500 valves on chevy. No grinding on heads.**  
**All heads have to have casting #s.**  
**May have screw in studs except 602 crate motors. 3/8 studs only.**

9. Carburetor must be 7448, 350 cfm Holley 2 barrel with choke removed. **NO** spacers, 1" adapter only. **NO** cold air boxes. **NO** tongue type air cleaners.
10. Stock automatic transmission may run remote cooler, stock converter. May run power glides, Straight shift transmission with 100 lbs penalty. No Muncie transmissions or aluminum transmissions in Chevys. Fords and Chrys may run aluminum transmissions. Stock type clutch and pressure plate, L-88 fly wheel on Chevys. **NO ALUMINUM.** Must have Blow Proof Bell Housing, cut out on bottom for inspection. No stock Bell Housing. Straight Shift cars need to be inspected before they race. May run hydraulic throwout bearing and pedal.
11. Stock rear end for make, any gear (may change ratio). Mini spools or welded (**NO** lockers) or limited slips.
12. Battery can be in drivers compartment if covered.
13. Stock ignition must be self starting. **NO** electric fuel pumps.
14. Engine must be in stock position, **POSITIVELY NO** engine set back

### **SUSPENSION**

1. Stock spindles for year and make of car
2. May run tubular upper A-frames
3. Springs may be replaced but must remain in stock location. Leaf spring cars must have same number of leafs on both sides, no composite springs allowed.
4. Wedge Bolts allowed in rear and hidden screw adjusters in front.
5. Shock must remain stock. **NO** racing shock such as AFCO, PRO, Bilstein, Carrea. Number must remain on shock or it is illegal. One (1) shock per wheel in stock location.
6. Frame no lower than 6" from ground.
7. **NO** offset cages.
8. Sway bar may be hooked up like the modified or outlaw late models
9. 9" Ford rear ends ok (NO Floaters)  
May run disc brakes. Front and rear

### **BODY AND APPEARANCE**

1. Windshield may be replaced with Lexan
2. May cut for wheel clearance. Full stock body, door jams, firewall. Floor pan must remain stock. Trunk lid and roof may NOT be hulled. Hoods may be hulled. May cut hole in hood for air cleaner. Dash may be made of steel or aluminum and **MUST** reach from one side to other. Doors may be made out of aluminum
3. Body must be stock and in stock position on frame. **NO** lowering, narrowing or chopping.
4. Car must have neat appearance. **AFTER MARKET NOSE AND TAIL PIECES MAY BE RUN.**
5. Car must be safe in all ways possible (See General Rules).  
Cars will not run with header panels missing over 1 week

6. May have 4" posts and 3/16 plate on door.
7. Roll cages recommended in driver compartment.

Ok to add bars under hood or trunk.

8. Numbers must be at least 20" tall and non reflective. Must contact Sandra Parker (798-2171) for car number available in your class.  
**NO duplicate numbers. NO Letters**

### **WHEELS, BRAKES & TIRES**

1. Steel wheels only 7" or 8", 3" offset wheels only.  
Same offset on all 4 wheels.
2. Disc brake on front and rear ok. **NO** Neal pedals for brakes.  
One master cylinder.
3. **TIRES:** Track tires. American Racer KK-704

Tires must be purchased from Sayre Speedway dealer and must have Sayre seal stamped on tire

**SOAK RULE NO** Soaking or altering of tire in any manner allowed. Drivers soaking or altering tires will forfeit all purse and points for event and all points for year.

### **PROTEST**

All protest must be handled in orderly manner. Refer to General Rules.

\$150 to see top end,

\$150 to see bottom end.

\$50 to pull intake,

\$25 to check wheels.

\$100 to pull oil pan

\$300 covers complete motor and flywheel and clutch or torque converter

NO Two way radios

For rule information, call David Morrow, (205)706-8814.

## **ROAD RUNNERS 2020 (TENTATIVE)**

American made 2 or 4 door sedan or station wagon. V-6 front wheel drive cars or V-6 trucks. American made Ranger, S-10, Explorer, Blazers, Dakotas, Durangos. 4-cyl cars Cavaliers, Alero, Sunfires, Avengers. CARS; Tarus, Impala, Malibus, Regals, Olds Cutlass, Monte Carlo, Grand Prix. NO SPORTS CARS

### **DRIVE TRAIN AND ENGINES**

1. Completely stock, NO altering of any kind
2. Horn must blow
3. Radio must work
4. Gauges must work (Factory ones). Dash must be stock for car
5. May have Quick Release Steering wheel and shaft (goes with car)
6. Seat Belts (mandatory). Fire Extinguisher also mandatory
7. NO hulling of any kind, except driver door for roll cage
8. Must have post and plates if you don't have roll cage
9. Roll cages recommended
10. Stock wheels and tires for cars, trucks and SUVs. Book size for base models. Must have proof of stock size tires.
11. Must have owners manual in glove box of truck or car. If owners manual not available must have proof of stock size in glove box, (i.e printed off internet.)
12. Engine stock for make and model.
13. NO headlights or side glass in cars
14. NO adding camber of any kind
15. DO NOT take anything out from under the hood.
16. May lean front tires in for wear. 2 degrees on right front only

Cars may be run in either direction at any time. This means practice or race

### **CLAIM RULE**

\$1,000.00 Claim on car or truck minus safety equipment, seat belts and cages if bolted in. If welded goes with car. The winner is only car on track that can be claimed.

This is a new class. Track has the right to modify rules as needed.

This is going to be a class for fun and entertainment. ANYBODY can run this division and run another division the same night. AGAIN THIS CLASS IS FOR FUN

Persons who can drive in this division are at track discretion.

## 2020 LIMITED MODIFIED RULES (TENTATIVE)

### ENGINE:

1. No engine larger than 350 cu in. .060 over OEM Blocks only. Must have casting #'s on block. Engine set back 72" from back of block to center of rear end housing.
2. **CRANKSHAFT:** Stock stroke, Cast Eagle or Scat cranks ok (No stroker cranks)
3. **RODS:** Must be stock appearing rods
4. **PISTONS:** Flat-top pistons only (no Dome pistons) .060 max. bore.
5. **HEADS:** Cast iron heads only (No vortex, 305, double hump or closed chamber heads. Casting # (39863336), (333882), (462624), 3932441), (3973487), (3998993), (3973493), (932441) 1.940 intake valves, 1.500 exhaust valves on all heads Chevy, Ford, Dodge. No grinding or porting on heads. **NO** matching intake.
6. **INTAKE** Typhoon or Edelbrock 7101 Performer RPM. **NO** matching, grinding or porting on intake.
7. **ROCKER ARMS:** Roller Rocker arm allowed. 1.5 on Chevy; 1.6 on Ford. Numbers must be on Rocker Arms.
8. **CAMSHAFT:** Hydraulic cam only. (**NO** roller Cams) 490 lift max. with .010 tolerance.
9. **CARBURETOR:** 350 2 barrel stock, choke may be removed. Must check with gauges at any time before or after race. 1" adaptor only.
10. **DISTRIBUTOR:** HEI stock type or MSD OK to run.
11. **HEADERS** may be run.

### SUSPENSION and DRIVE TRAIN

1. Stock type ball joints.
2. **SHOCKS:** Steel shocks only. **Fix Bearing type SHOCKS** or (WB Series) or (FB Series) type only.  
**Buy rule on shocks.** May buy front shocks \$160 or rear shocks \$160. (Front and rear \$320)
3. **DRIVE SHAFT:** Steel only
4. **FRAME HEIGHT:** 4" at lowest point (Except cross members)
5. **REAR END:** 9" Ford allowed, Floaters allowed. Mini-spool or full spool only. (No quick changes) **NO** Lockers



6. **TRANSMISSION:** 3 or 4 speed only, no racing transmission (like Tex, Jerico, Bert, Falcon, Brinnn)
7. **FUEL CELL:** Must be at least 8" from ground and have at least 2 1" straps around it.
8. **CLUTCH:** 7 1/4", 2 or 3 disc type clutches allowed only.

### **WHEELS, BRAKES AND TIRES**

1. 8" Steel Wheels only
2. Tires: Track Tires

Tires must be purchased from Sayre Speedway dealer and must have Sayre seal stamped on tire.

**SOAK RULE NO** Soaking or altering of tire in any manner allowed. Drivers soaking or altering tires will forfeit all purse and points for event and all points for year.

NO two way radios

### **PROTEST**

All protest must be handled in an orderly manner. Top end protest \$200.00. This checks for flat-top pistons, bore, stroke, ported heads, size of valves and cam lift. To pull intake is \$100.00. This checks cam lift and ported and polished heads. \$150 to pull oil pan and see crank and rods.

Drivers that can run this division will be at track discretion.

### **WEIGHT RULE**

1. 2500 lbs after race with driver.
- 2.. Weight may be added for minor infractions

**IF THESE RULES DO NOT STATE YOU CAN DO IT, YOU CANNOT.**

This division is based on keeping this class inexpensive like the Street Stock. Remember - Keep it cheap.

## LIMITED MODIFIED BODY DIMENSIONS FOR 2020

- A. 20" max 16" min. (ground to center of bumpers, front and rear)
- B. 6.5 min. (center to center)
- C. 52" max. 42" min.
- D. Hood 4" max. drop (sides). sealed off from driver's compartment and max. 3" rake.
- E. 42" max.
- F. 6" max.
- G. 4" min.
- H. 19" max., must be same on both sides.
- I. 112" max. 105" min.
- J. 27" max 22" min.
- K. 72" max. or not past back of block, right side. Left side may extend forward to cover foot box
- L. 18" max. 12" min. opening, both sides.
- M. With level, must have between 1/2" and 2" clearance at rear of roof, 1/2" to 5" at front.
- N. 120" max. 106" min.
- O. 48" max. 34" min.
- P. 5" Spoiler
- Q. Interior slope is 6" max. front to rear and flat across. If flat at front half of interior you have used up 50 % of your 6" so from behind driver to rear you may only have 3". Top of interior must be flush with top of door and quarter panels. An optional escape hatch from driver to passenger door to provide 12" opening allowed.
- R. 38" max 28" min.
- S. Max. no wider than front frame horns. Min. 24"
- T. 66" max. 24" min. no narrower than radiator.
- U. 52" max 44" min.
- V. 56" max. 41" min.
- W. Tires must be widest part of car.
- X. 66" max. 53" min.
- Y. All rear bumpers must be constructed of square or round tubing, no wider than five inches outside of rear frame rails and similar to drawing. If rear bumper is wider than five inches outside rear frame rails, it must be constructed in a loop design like drawing

Shaded area reserved for sponsor decals. MUST DISPLAY ALL DECALS TO BE ELIGIBLE FOR ANY CONTINGENCY AWARDS OR POINT FUNDS.

(P) 5" Spoiler

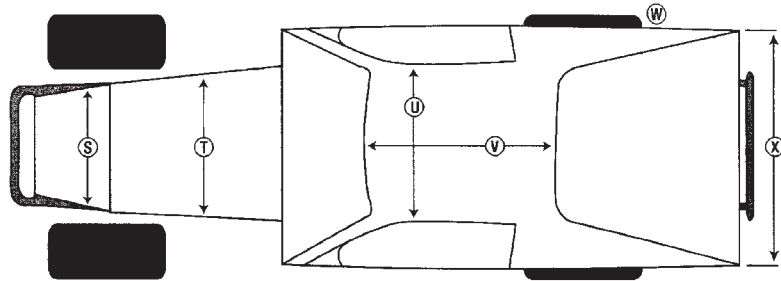
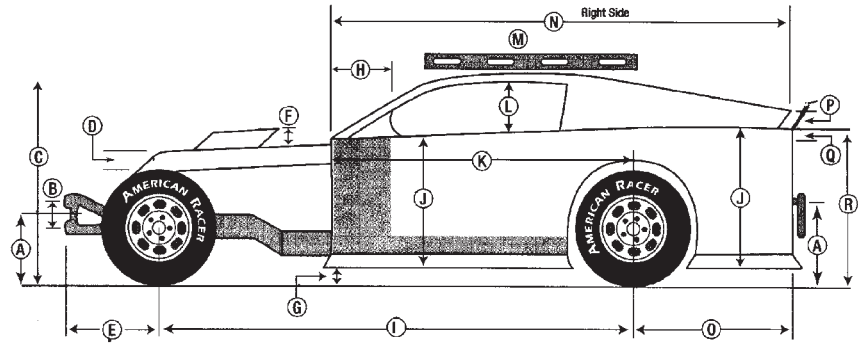

Sail Panels

Sail Panel

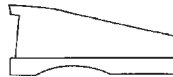

Rear Bumper

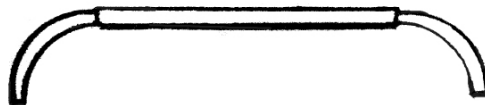

## 2020 MINI MODIFIED (TENTATIVE)

**THE INTENT AND INTERPRETATION OF THE RULES WILL BE THE DECISION OF OFFICIALS IN CHARGE. IT IS STRONGLY RECOMMENDED THAT ANY COMPETITOR THAT HAS ANY QUESTIONS OR DOUBT ABOUT THE INTERPRETATION OR INTENT OF THE RULES CHECK WITH SPEEDWAY OFFICIALS. ALL DECISIONS OF THE OFFICIAL IN CHARGE SHALL BE FINAL.**

### CARS LEGAL FOR DIVISION

Any 4 cylinder, 2 or 4 door (4 passenger) sedan, or station wagon foreign or domestic - between 90" and 105" wheel base.

**FUEL CELL** - Fuel cell **REQUIRED**. Must be mounted securely with 10" (ten inch) ground clearance. **ALL CARS** will have a fire wall between driver and fuel cell.

### ENGINE AND DRIVE TRAIN

1. Engine must be factory stock for make and model of car in stock position.
2. 2000 lb. minimum after race. Mustang with stock appearing body must weigh 2150 lbs. Mini Modified type cars with coil over type shocks and fiber glass bodies will have to weigh 2250 lb. Front Wheel drive weight: 2200.
4. Engine can be balanced.
5. May run after market rods
6. Lightening of crankshaft ok. Must be Stock stroke.
7. Anything can be done to the head. May be ported and polished and run any valve size. Fords may run aluminum head.
8. Any aluminum intake with maximum of 2" from intake to carburetor.
9. May run roller cam and rockers on Fords. Toyotas may run roller rockers.
10. Exhaust headers optional.
11. May run single or double disc type clutches such as 10,000 RPM or Goldstar, or Tilton with Aluminum Flywheel.
12. Stock transmission and rear ends. (Locked rear ends optional)
13. Carburetor stock 350 CFM (7448) Holley Carburetor. Must fit gauges. May remove choke plate. **No** cold air boxes.
14. Battery can be located behind driver but must be covered if run there. Must be self starting.

### BODY AND APPEARANCE

1. Bodies may be fiberglass or Aluminum

May cut holes in hood for air cleaners. Must check with official before running.  
Stock, firewall and floor pan (front and rear).

2. Stock size windshield. Side windows no more than 12 inches back on each side.
3. Safe steering shaft.
4. Dash may be made with steel or aluminum. Must reach from one side to other side.
5. Car must be safe in all ways possible. (See General Rules)
6. Car must have neat appearance
7. Spoiler - 5" spoiler

### **WHEEL, TIRES, BRAKES AND SUSPENSION**

1. Steel wheels. 8"
2. **TIRE RULE:** Track tires

Tires must be purchased from Sayre Speedway dealer and must have Sayre seal stamped on tire

**SOAK RULE NO** Soaking or altering of tire in any manner allowed. Drivers soaking or altering tires will forfeit all purse and points for event and all points for year.

3. Stock brakes. Can run adjustable brake pedals
4. Stock suspension required in stock position - may be reinforced. A-frames can be shortened or lengthened to set front-end. May run Jack Bolts in rear.
5. Weight may be added for minor infractions
6. Heim joints legal on suspension

### **CLAIM & PROTEST**

All protest will be handled in an orderly manner. Refer to General Rules. You have 10 minutes to protest after the race.

NO Two way radios

THE **WINNER** FROM THE **LAST RACE** WILL **START** NO BETTER THAN 9TH PLACE

**Buzz cars with fuel injection may move up to mini modified if needed. Weight starts at 2150 lbs with mini modified tires**

## 2020 RENEGADE (TENTATIVE)

**THE INTENT AND INTERPRETATION OF THE RULES WILL BE THE DECISION OF OFFICIALS IN CHARGE. IT IS STRONGLY RECOMMENDED THAT ANY COMPETITOR THAT HAS ANY QUESTIONS OR DOUBT ABOUT THE INTERPRETATION OR INTENT OF THE RULES CHECK WITH SPEEDWAY OFFICIALS. ALL DECISIONS OF THE OFFICIAL IN CHARGE SHALL BE FINAL.**

**DRIVERS** - Drivers that can run this division will be at track discretion.

### CARS

104" Wheel base minimum. No low profile (such as Camaro, Firebird, Mustang). Monte Carlo, Cutless, Regals can run 350 Chevy engine or what came in car. May run V-6 front wheel drive cars also with book size tires and rims and can be fuel injected. V-6 cars may run straight shift transmissions. ALL GM cars can run 350 Chevy engines.

### ENGINES AND DRIVE TRAINS

1. Stock block, crank, rods and heads. NO porting or polishing. May be bored. Hydraulic camshafts only. NO roller cam motor unless V-6. Cars must pull 16 1/2 inch of vacuum + or - 1/2". Car must have air cleaner. GM cars must run #7448 stock Holley 350 2 barrel carburetors. Fords and Dodges can run a Holley 500 carburetor #4412. NO altering metering block. Must remove choke flaps. NO Keith Dorton Carburetors
2. EXHAUST - Shorty headers may be run on all cars
3. TRANSMISSION Stock automatic, with stock size torque converter 11"

### BODY FRAME AND SUSPENSION

1. Body stock in every way - 4 door or 2 door. Side glass must be removed. Doors must be welded or strapped shut. May replace windshield with lexan.
2. No frames lower than 6" (six inches)
3. Suspension must be stock type. NO independent rear suspension V-8 Cars
4. NO locked rear ends or limited slips

## **SAFETY**

**No restrictions will be made on safety. Anything may be added to car to make it safer.**

**Racing seat belts required**

**Full cage or plate and post required**

**1/4" plate on driver door. Must overlap the front fender at least 6" and the rear door or quarter panel at least 6". Must have (2) 4" post with plates on each end bolted to roof and floor pan behind driver seat**

**Fuel cell or 6 (six) gallon gas tank recommended.**

**Fire extinguisher must be in drivers reach.**

**Bumpers must be chained with bolts or welded to prevent them from coming off.**

**NO glass except front windshield**

## **APPEARANCE**

**All cars must have neat appearance. Header panels will have to be replaced within 2 weeks. Number must be readable to be scored. Non-reflective and contrasting (example light color numbers on dark car, dark numbers on light car). NO THREE DIGIT NUMBERS. NO LETTERS. NO EXCEPTIONS**

## 2020 LATE MODEL (TENTATIVE)

**THE INTENT AND INTERPRETATION OF THE RULES WILL BE THE DECISION OF OFFICIALS IN CHARGE. IT IS STRONGLY RECOMMENDED THAT ANY COMPETITOR THAT HAS ANY QUESTIONS OR DOUBT ABOUT THE INTERPRETATION OR INTENT OF THE RULES CHECK WITH SPEEDWAY OFFICIALS. ALL DECISIONS OF THE OFFICIAL IN CHARGE SHALL BE FINAL.**

### CHASSIS

Tubular Frame cars w/coilovers

Built Motor Cars and 604 Crate Cars 2750

602 Crate Motor 2600

1 lbs per lap burn off

### LEFT SIDE WEIGHT

58%

59%

### ENGINE RULE

Cast iron blocks only.

Engine compression cubic inch not limited

One Carburetor (any size)

### CLUTCH AND TRANSMISSION

Must have forward and reverse gears

### WHEELS, TIRES

10" Steel wheels only (any offset)

Track Tires- Tires must be purchased from Sayre Speedway dealer and must have Sayre seal stamped on tire

### SHOCKS AND SPRINGS

Any Shock and Springs

Bump Stops OK

### FUEL CELL

Fuel cell mandatory. 8" minimum ground clearance. Must have 2 straps across top of cell to protect cell.

### BODY

Any late model bodies or outlaw type bodies no wider than 82".

### SPOILER

6 1/2" Spoiler

Two way radios will be allowed for safety reasons. Track reserves the right to take away from any driver using them for wrong reason.

If you have questions call Bary Martin (205) 674-0367  
For Race Car Numbers, call Sandra Parker (205) 798-2171









