

## GENERAL RULES

**\*THE INTENT AND INTERPRETATION OF THE RULES WILL BE THE DECISION OF OFFICIALS IN CHARGE. IT IS STRONGLY RECOMMENDED THAT ANY COMPETITOR THAT HAS ANY QUESTIONS OR DOUBT ABOUT THE INTERPRETATION OR INTENT OF THE RULES CHECK WITH SPEEDWAY OFFICIALS. ALL DECISIONS OF THE OFFICIAL IN CHARGE SHALL BE FINAL.**

Unless otherwise stated in a particular division, **these general rules apply to all divisions.**

## SAFETY

**NOTE: The following safety rules set forth by the SPEEDWAY do not guarantee prevention of personal injury, but are a guideline to building a safer racing vehicle.**

- A. Fuel cells are required. The maximum capacity allowed is 22 gallons. Fuel cell must have a working check valve and foam.
- B. Fuel cell must be mounted equal distance between rear frame rails and at least 8" above ground.
- C. Fuel cell vent and overflow may not exceed 1" in diameter. Overflow must exit at rear of car.
- D. Fuel cell must have four (4) 1/8" x 1" straps under cell and at least two (2) on top of cell bolted to fuel cell frame.
- E. Fuel cell must be protected at rear by 1-1/2" roll bar tubing extending below rear of frame 1/2" beyond bottom of cell and the width of the cell, with one (1) center brace.
- F. Fuel line must be run in metal tubing or metal conduit from cell to pump.  
No electric fuel pumps permitted.
- G. Cars must have fire extinguisher on-board in working order with gauge.  
Must be in driver's reach. Driver responsible for updating.
- H. Drive Shaft and Bolt on Lead or Ballast must be painted white.
- I. Window Net required. Must release from top and mount on roll cage at bottom.
- J. Steering Wheel must be padded at center. Release hub recommended.
- K. All Roll Bars in driver's reach must be padded.
- L. No open holes in floor pan or firewalls permitted.
- M. **Five (5) Point Harness System with 3" lap belt and shoulder harness required.**
  - 1. Both ends must be fastened to roll bar cage of car with aircraft quality bolts, no less than 3/8" in diameter.
  - 2. A steel plate may be welded to roll bar cage on right side of driver so that the belt can be brought down in such a manner that it will keep the driver from sliding from side to side under the belt.
  - 3. The belt must come from behind the driver over roll bar.
- N. At least two (2) return springs required on throttle.
- O. Switches must be within driver's reach with belts on.
- P. Helmets are required and should meet Federal Motor Vehicle

Safety Standards.

- Q. All drivers are required to wear approved flame retardant suits and gloves during all practice, qualifying and race conditions. (NO Coveralls)**
- R.** Radiator overflow must be run up to windshield so driver or official can see water in case car runs hot.
- S.** Absolutely **NO ANTIFREEZE** in coolant system.

### **ROLL CAGE**

1. Steel Roll bars must be 1 1/2" outside diameter minimum.
2. Four (4) bars are required on driver's side extending from main cage to door, three (3) bars on right side. All seams and joints must be welded solid.
3. Roll Cage must be approved by SPEEDWAY officials before entering race track.

### **SEATS**

1. Bucket seats are mandatory and must be approved. Seats may be fiberglass or aluminum, bolted to seat frame attached to roll cage.
2. Seat must be high back with padded head rest.
3. Location of seat cannot extend past rear of door.

### **APPEARANCE**

1. All cars must be neatly painted and maintained.
2. Numbers must be at least 24" on both right and left side of car. No Silver or Gold numbers. **TWO NUMBERS ONLY. NO LETTERS**
3. **NO duplicate numbers.** Numbers have to be assigned through the track. Duplicates will be reassigned at track discretion.  
For number Call: Sandra Parker 798-2171 or 999-3510.

### **PROTESTS**

- A.** Only drivers can appoint someone to inspect car or protest. Protestng driver must compete in feature race. No protesting anyone finishing behind you. All protest must receive approval of Chief Pit Steward. Spite protest or protest done in an unsportsmanlike manner will not be accepted. Protest must be made within 10 minutes of feature. You have 45 minutes to be ready to be teched.
- B.** Visual protest (requiring no measurements whatsoever) must be presented to Chief Pit Steward in writing BEFORE THE DRIVERS MEETING starts. \$30.00 non refundable charge.  
**NO VISUAL PROTEST CAN BE MADE AFTER THE RACE IS OVER.**
- C.** All other protest or claims must be presented to Chief Pit Steward in writing within 10 minutes of finish of feature race accompanied by \$150.00 per protest; \$25.00 is given to the person designated to make measurements; and \$125.00 to the driver who wins the protest.
- D.** Driver of cars found illegal forfeit points, money earned and will start on rear the next race they attend.

### **ENFORCEMENT**

- A. The fact that an infraction is not noted does not make it legal.**

- B. Chief Pit Steward may add weight for infractions that create an advantage.
- C. The Chief Pit Steward has the final word on any rule or protest.
- D. All problems will be handled in a calm and sportsmanlike manner. Anyone not conducting themselves in a sportsmanlike manner may have their license revoked for an indefinite period of time.
- E. Loose lead found on any car after race will automatically disqualify car. **(NO Excuses)**
- F. Can be black flagged for dragging pieces. Will need to be checked for safety by pit official.
- G. If you spin someone out, **BOTH** cars will be sent to rear.
- H. **NO** 2 Way Radios will be allowed

### **CONDUCT IN PIT AREA**

- A. Drivers and/or car owners are responsible for their entire pit crew.
- B. **ABSOLUTELY NO DRINKING BY ANYONE WILL BE ALLOWED IN THE PIT AREA.**
- C. Any pit crew member or anyone else in the pit area who violates the above stated rule will be in contempt and be fined \$50.00. In addition, the driver will lose all winnings and points for the event, and will be suspended from the next racing event.
- D. Drivers and crew members will conduct themselves in a calm and sportsmanlike manner at all times. Any one throwing anything will be Fined & Barred. Minimum Fine \$100.
- E. Any crew member or fan in the pit area who uses loud and abusive language towards a pit crew member or track official, or any individual who is guilty of starting or **engaging in a fight will be fined a minimum of \$100.00.** In addition, the driver will lose all winnings and points for the event, and could be suspended from the next 2 (two) racing events. According to severity, suspension can be indefinite. Anyone hitting a track official will be fined \$200 and suspended. Family or fans coming out of stands will automatically cause driver to lose points and money for that night.

### **FUEL**

The only approved fuel for operation of any racing vehicle on the SPEEDWAY is racing gasoline. ALCOHOL OR NITROUS IS STRICTLY PROHIBITED. Violations subject to a fine of \$200.00.

**NOTE:** The SPEEDWAY reserves the right to modify/change rules during the season as deemed necessary for safety, fair competition, or any other reason that track officials feel may be appropriate.

**TRACK HAS THE RIGHT TO BAR ANYONE WE FEEL IS BEING DETRIMENTAL TOWARDS THE TRACK OR DRIVERS THROUGH SOCIAL MEDIA OR ANY OTHER MEANS.**

GENERAL RULES Continued

**ATTENTION ALL DRIVERS**

**NO PROFANITY ON CARS. NO SUGGESTIVE ART WORK ON CARS.**

Drivers **MUST** purchase a yearly membership pit license before you race.

This year we will award points for the top five in all divisions.

Points will be awarded in each division you race in. Therefore you **MUST PURCHASE** a membership pit license for each division you race in.

**YOU CANNOT** race in 2 (two) divisions in the same night except for the Hoggs and Road Runners. Anyone may run these divisions as long as you have a **MEMBERSHIP** for **EACH CLASS** you race in.

**YOU CANNOT** race in Buzz once you move up from this divisions.

Buzz is a beginner division.

Anyone wishing to move down to street stock must check with track official before you race. Driver moving down is at track discretion.

## 2019 OPEN WHEEL MODIFIED

**THE INTENT AND INTERPRETATION OF THE RULES WILL BE THE DECISION OF OFFICIALS IN CHARGE. IT IS STRONGLY RECOMMENDED THAT ANY COMPETITOR THAT HAS ANY QUESTIONS OR DOUBT ABOUT THE INTERPRETATION OR INTENT OF THE RULES CHECK WITH SPEEDWAY OFFICIALS. ALL DECISIONS OF THE OFFICIAL IN CHARGE SHALL BE FINAL.**

### **GENERAL**

1. American made frames 105" wheel base minimum
2. Cars must weigh 2550, 1 pound per lap burn off
3. Rear of engine must be mounted 72 inches forward from center line of rear axle.  
Engine offset within 2" of center of crossmember.
4. 2 way radios will be allowed for safety reasons. Track reserves the right to take away from any driver using them for wrong reason

### **WEIGHT:**

2550 Minimum 58.0% Left side max for Steel Head Built engines.

2600 Minimum 58.0% Left side max for Aluminum Head Built engines.

**NO titanium products, parts or components allowed on chassis or suspension.**

No gun-drilled, tubular or hollow bolt or studs anywhere on car.

### **ENGINES**

**NO** aluminum blocks. No Dry Sump Systems. Aluminum heads must bolt 50 lbs. in front of bell housing.

### **CARBURETOR**

One 2 barrel or 4 barrel only.

### **FRAMES**

Must maintain 4" ground clearance at all times. Factory production complete full 1960 or newer parallel American passenger car frames only with a Minimum wheelbase 108". Frames may be cut in rear only at point not further than 36 inches from center of rear end housing. Frames may not be widened or narrowed. Must be full and complete both sides.

## **SUSPENSION AND STEERING.**

Front steering must be unaltered approved OEM and be in stock location, and must be replaceable by OEM appearing parts. Tie rod ends and adjustment sleeve may be replaced by a minimum .625-inch rod end and steel tube. Stock passenger car spindles or fabricated spindles must be steel. Bottom A-frames cannot be altered or moved. Front sway bar must be stock appearing and diameter of 1 3/8" maximum. Steering parts must be steel approved OEM and must remain within original bolt pattern for type of frame used. **NO** rack & pinion allowed. Coil over kits with minimum of 4.5" springs on rear only. **NO** bump stops, coil binding or chassis stops allowed, maximum 2 spring rubbers per spring and a minimum of 500 pound front spring rate. **NO** driver adjustments from cockpit except for brakes.

## **BRAKES**

Must be steel, approved OEM APPEARING calipers, and cannot be lightened. Steel vented rotors only, no scalloped rotors. Rotors cannot be lightened.

## **BODIES**

All body rules are at the discretion of tech official. Must be full size roof. (Must cover halo) Body sides must be straight front to back with a maximum length of 120" starting from back of engine, maximum width of 66" and body rake of 6" must be straight front to rear and flat. Asphalt type nose piece allowed no wider than 43 1/2 inches. Engine compartment must remain open. Passenger side of body must be no further forward than rear of engine. Right side "A" posts must be within 8" of right side of car or 50 lbs. penalty. Wing window not included in measurement. Interior wings, belly pans, double skinned roofs, fins, wings, vanes, vertical ledges, ramps or any other air directing devices are not allowed. 12" MAX length triangular enclosure at the 'A' pillar will be allowed. All cars are required to have side nerf bars mounted even with outside of tire. Must maintain 4" ground clearance at all times. Spoiler Max. 8"x 66" rear spoiler with maximum of 4 straight forward braces no longer than 16" Late model spoiler braces may be used front or rear of spoiler. Gurney flaps or curls are allowed but will be included in all measurements.



## IGNITION

MSD or Crane Ignition boxes allowed. **NO** traction Control. 7600 rev limiter required

## FUEL

Sunoco Racing Fuel **ONLY**. **NO** performance-enhancing fuel additives of any kind. OBERG Fuel Line Safety Valve # SV-0828 required.

## TIRES AND WHEELS

8" steel wheels only. American Race Tire KK-704 With Sayre and Huntsville Stamp. **SOAK RULE: NO** Soaking or altering of tires in any manner allowed. Drivers soaking or altering tires will forfeit all purse and points for event and all points for year. Driver must also pay a \$1,000 fine prior to racing again. All illegal tire (decision by track official) will be confiscated.

## SAFETY

1. Fuel cell required. 22 gallon max. It must not be lower than rear housing.
2. Left side window net required.
3. Seat belt and shoulder harness required. All belts must be quick release types. Harness must be type that comes individually over both shoulders. Racing seat only. Seat must be bolted or welded to roll cage.
4. Two (2) drive shaft supports are required. **NO** carbon fiber drive shafts permitted. Drive shaft must be painted white.
5. Fire suits, Gloves, Approved Helmet required.
6. Roll Bar padding required within all areas of drivers reach
7. Must have minimum 2-pound fire extinguisher with a gauge and a quick release mounted securely in car within reach of driver while belted in car.
8. All weight (lead) must be mounted above frame/inside frame rail with a minimum of two (2) 1/2 inch bolts. All weights are to be painted white or florecent with the car # painted on each piece. Any driver that loses any lead from his/her car will be fined \$10.00 per pound payable prior to any further competition. This rule is in effect during race day or practice days.
9. **NO** Titanium. Lines to fuel pressure gauge must be steel braided type.
10. OBERG Fuel - Line Safety Valve #SV-0828 required.
11. TRACK OFFICIALS must approve all safety equipment.

## OPEN WHEEL MODIFIED BODY DIMENSIONS FOR 2019

- A. 20 "max 16" min. (ground to center of bumpers, front and rear)
- B. 6.5 min. (center to center)
- C. 52" max. 42" min.
- D. Hood 4" max. drop (sides). sealed off from driver's compartment and max. 3" rake.
- E. 42" max.
- F. 6" max.
- G. 4" min.
- H. 19" max., must be same on both sides.
- I. 112" max. 108" min.
- J. 27" max 22" min.
- K. 72" max. or not past back of block, right side. Left side may extend forward to cover foot box.
- L. 18" max. 12" min. opening, both sides.
- M. With level, must have between 1/2" and 2" clearance at rear of roof, 1/2" to 5" at front.
- N. 120" max. 106" min.
- O. 48" max. 34" min.
- P. Spoiler 5"
- Q. Interior slope is 6" max. front to rear and flat across. If flat at front half of interior you have used up 50 % of your 6" so from behind driver to rear you may only have 3". Top of interior must be flush with top of door and quarter panels. An optional escape hatch from driver to passenger door to provide 12" opening allowed.
- R. 38" max 28" min.
- S. Max. no wider than front frame horns. Min. 24"
- T. 66" max. 24" min. no narrower than radiator.
- U. 52" max 44" min.
- V. 56" max. 41" min.
- W. Tires must be widest part of car.
- X. 66" max. 53" min.
- Y. All rear bumpers must be constructed of square or round tubing, no wider than five inches outside of rear frame rails and similar to drawing. If rear bumper is wider than five inches outside rear frame rails, it must be constructed in a loop design.



Shaded area reserved for sponsor decals. MUST DISPLAY ALL DECALS TO BE ELIGIBLE FOR ANY CONTINGENCY AWARDS OR POINT FUNDS.

(P) 5" Spoiler

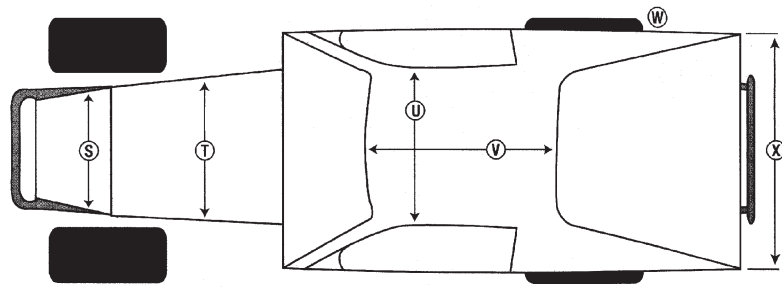
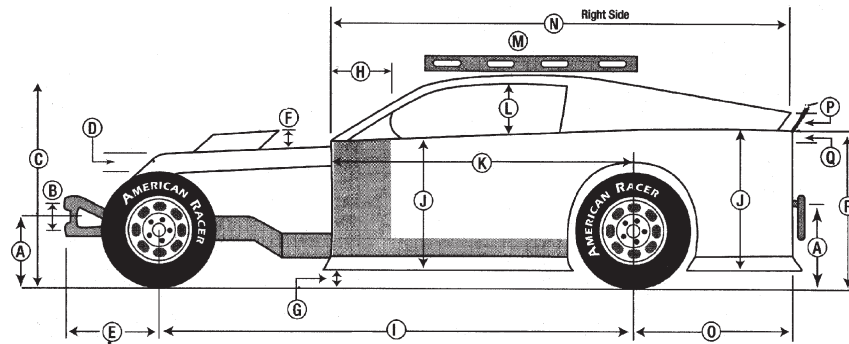

Sail Panel



Sail Panels

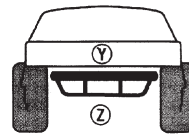

Rear Bumper

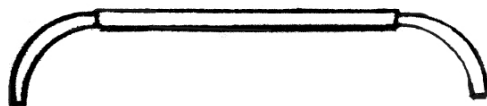

## 2019 BUZZ RULES MOTOR RULES

Motor must have been available for make and model of auto claimed. Motor may be a newer version of motor for claimed auto but must be same "L" Liter. (Example: You may use a 3100 for a 3.1L. Another example: You have a 1994 Acura Integra with a B18C1 you may use a motor from a 2000 Honda Integra JDM B18C Type-R) ECM must still remain stock for year make and model.

**TRANSMISSION:** Transmission must have been available for make, model and year of auto "claimed". NO MIS-MATCH OF MOTOR & TRANSMISSION

Plug wires: Optional 7mm or 8mm

Must run stock ignition coils-modules, chips, etc. (NO MSD)

**HP:** There is no limit on HP

Weight must be added for anything over 190 HP. Weight/HP ratio is 1lb/HP (Example: 205HP must add 15 lbs)

Weight must be mounted in the center of the passenger side where seat was previously mounted. For safety purposes must use grade 5 or stronger bolts with lock nuts to mount weight.

**REMEMBER:** If it doesn't say you can do it, you can't. Some things you will be able to call and get permission on to run. If this happens it is advisable for you to have this in writing and signed and dated from a Tech Official

4 cylinder - Automatic or Standard

6 cylinder - Automatic

American or Foreign stock cars Front Wheel Drive ONLY

**NO** high performance models

**NO** turbo or supercharged cars allowed.

**NO** NOS or other performance enhancing devices allowed

Door hinges, locks, and side impact bar must remain in door

Doors must be securely fastened shut

Must remove all glass

\*If using a glass windshiled must wear goggles or face shield

May use screen or lexan - must be completely across windshield area

May remove back seat, carpet, headliner, and trim panels

**NO** leaning rear tires)

May run Max 2" spacer on right side to prevent tire scrub only

Four (4) point roll cage MANDATORY

### **SEAT**

Racing seat

Seatbelt - 5 point harness

Must cover all holes in front and rear firewall and floorboard.

### **FUEL CELL OR GAS TANK**

Fuel Cell must be centered in rear of the car no lower than the frame

May run Road Runner cars combined with Buzz if car count is not enough



## 2019 STREET STOCK

THE INTENT AND INTERPRETATION OF THE RULES WILL BE THE DECISION OF OFFICIALS IN CHARGE. IT IS STRONGLY RECOMMENDED THAT ANY COMPETITOR THAT HAS ANY QUESTIONS OR DOUBT ABOUT THE INTERPRETATION OR INTENT OF THE RULES CHECK WITH SPEEDWAY OFFICIALS. ALL DECISIONS OF THE OFFICIAL IN CHARGE SHALL BE FINAL.

1. Anything not specified in Rules must be stock, in original position, from original manufacturer.
2. American made cars from 106" to 114" wheel base. **NO** Camaros or Mustangs. May run T-Bird
3. Cars must weigh minimum of 3100 lbs. with driver after race. 56% left side weight max. Weight may be added for minor infractions.
4. 360 cubic inch - NO 400 small blocks.
5. 602 Crate Engine will be allowed. Must run by GM spec.

### ENGINE & DRIVE TRAIN

1. No engine larger than 350 CI .060 over OEM blocks only. Must have casting numbers on block.
2. CRANKSHAFT: Stock stroke, cast eagle or scat cranks OK (NO stroker cranks.)
3. RODS Must be stock appearing such as Eagle (SIR) or the Scat Rods
4. PISTONS: Flat-top pistons only (No Dome pistons)
5. CAM SHAFT: Hydraulic camshafts only. Stamped steel rocker arms.  
**3/8 studs only in all heads.**  
**NO roller Rockers (NO roller tip rockers)**
6. INTAKE: Stock aluminum intake. **NO** hi rise intakes.  
Chevys can run intake #2101  
Fords can run 2750 or windsor 2181
7. **HEADS: May run double hump, Vortec, 305 heads with 1.940 intake valves 1.500 exhaust valves. 62cc min. on Vortec or Double Hump intake # for Vortec heads is #2716. Any other intake 50lb penalty (NO porting or polishing) with 100 lbs penalty. Fords can run the GT 40 heads with 100 lbs penalty.**  
**Stock size valve springs only. Other heads that can be run casting # will have to be on heads. Numbers for Chevy 350 are (398633361)(333882) (462524)(3973487)(3998993)(3973493) (932441) 1.990 1.500 valves on chevy. No grinding on heads.**  
**May run stock Aluminum intake. No hi rise intakes. Header maybe run. May cut center of intake out for 2 barrel. All heads have to have casting #s.**
8. **Weight may be added to make competition fair**

9. Carburetor must be 7448, 350 cfm Holley 2 barrel with choke removed. **NO** spacers, 1" adapter only. **NO** cold air boxes. **NO** tongue type air cleaners.
10. Stock automatic transmission may run remote cooler, stock converter. May run power glides, Straight shift transmission with 100 lbs penalty. No Muncie transmissions or aluminum transmissions in Chevys. Fords and Chrys may run aluminum transmissions. Stock type clutch and pressure plate, L-88 fly wheel on Chevys. **NO ALUMINUM.** Must have Blow Proof Bell Housing, cut out on bottom for inspection. No stock Bell Housing. Straight Shift cars need to be inspected before they race. May run hydraulic throwout bearing and pedal.
11. Stock rear end for make, any gear (may change ratio). Mini spools or welded (**NO** lockers) or limited slips.
- 12.. Battery can be in drivers compartment if covered.
13. Stock ignition must be self starting. **NO** electric fuel pumps.
14. Engine must be in stock position, **POSITIVELY NO** engine set back

### **SUSPENSION**

1. Stock spindles for year and make of car
2. May run tubular upper A-frames
3. Springs may be replaced but must remain in stock location. Leaf spring cars must have same number of leafs on both sides, no composite springs allowed.
4. Wedge Bolts allowed in rear and hidden screw adjusters in front.
5. Shock must remain stock. **NO** racing shock such as AFCO, PRO, Bilstein, Carrea. Number must remain on shock or it is illegal. One (1) shock per wheel in stock location.
6. Frame no lower than 6" from ground.
7. **NO** offset cages.

### **BODY AND APPEARANCE**

1. Windshield may be replaced with Lexan
2. May cut for wheel clearance. Full stock body, door jams, firewall. Floor pan must remain stock. Trunk lid and roof may NOT be hulled. Hoods may be hulled. May cut hole in hood for air cleaner. Dash may be made of steel or aluminum and **MUST** reach from one side to other. Doors may be made out of aluminum
3. Body must be stock and in stock position on frame. **NO** lowering, narrowing or chopping.
4. Car must have neat appearance. **AFTER MARKET NOSE AND TAIL PIECES MAY BE RUN.**
5. Car must be safe in all ways possible (See General Rules). Cars will not run with header panels missing over 1 week.
6. Core support will remain stock.
7. May have 4" posts and 3/16 plate on door.
8. Roll cages recommended in driver compartment.

Ok to add bars under hood or trunk.

9. Numbers must be at least 20" tall and non reflective. Must contact Sandra Parker (798-2171) for car number available in your class.

**NO duplicate numbers. NO Letters**

### **WHEELS, BRAKES & TIRES**

1. Steel wheels only 7" or 8", 3" offset wheels only.  
Same offset on all 4 wheels.
2. Disc brake on front and drum on rear. **NO** Neal pedals for brakes.  
One master cylinder.
3. **TIRES:** Track tires

Tires must be purchased from Sayre Speedway dealer and must have Sayre seal stamped on tire

**SOAK RULE NO** Soaking or altering of tire in any manner allowed. Drivers soaking or altering tires will forfeit all purse and points for event and all points for year. Driver must also pay a \$1,000 fine prior to racing again. Any illegal tire (decision by track official) will be confiscated.

### **PROTEST**

All protest must be handled in orderly manner. Refer to General Rules.

\$125 to see top end,

\$125 to see bottom end.

\$50 to check cam lift,

\$50 to pull intake,

\$25 to check wheels.

\$50 to pull inspection plug

NO Two way radios

For rule information, call Frank Martin 674-0924/674-0367. He has material for posts and parts for all your racing needs.

## ROAD RUNNER 2019

American made 2 or 4 door sedan or station wagon. V-6 front wheel drive cars or V-6 trucks. American made Ranger, S-10, Explorer, Blazers, Dakotas, Durangos. 4-cyl cars Cavaliers, Alero, Sunfires, Avengers. CARS; Tarus, Impala, Malibus, Regals, Olds Cutlass, Monte Carlo, Grand Prix. NO SPORTS CARS

### DRIVE TRAIN AND ENGINES

1. Completely stock, NO altering of any kind
2. Horn must blow
3. Radio must work
4. Gauges must work (Factory ones). Dash must be stock for car
5. May have Quick Release Steering wheel and shaft (goes with car)
6. Racing Seat and Belts (mandatory). Fire Extinguisher also mandatory
7. NO hulling of any kind, except driver door for roll cage
8. Must have post and plates if you don't have roll cage
9. Roll cages recommended
10. Stock wheels and tires for cars, trucks and SUVs. Book size.  
Must have proof of stock size tires.
11. Must have owners manual in glove box of truck or car. If owners manual not available must have proof of stock size in glove box, (i.e printed off internet.)
12. Engine stock for make and model.
13. NO headlights or side glass in cars
14. NO adding camber of any kind
15. DO NOT take anything out from under the hood.
16. May lean front tires in for wear.  
Max. 2" rim front tires only, NOT rear tires

May run with Buzz cars if not enough cars.

### CLAIM RULE

\$1,000.00 Claim on car or truck minus safety equipment, seat belts and cages if bolted in. If welded goes with car. The winner is only car on track that can be claimed.

This is a new class. Track has the right to modify rules as needed.

This is going to be a class for fun and entertainment. ANYBODY can run this division and run another division the same night. AGAIN THIS CLASS IS FOR FUN



## 2019 LIMITED MODIFIED RULES

### ENGINE:

1. No engine larger than 350 cu in. .060 over OEM Blocks only. Must have casting #'s on block. Engine set back 72" from back of block to center of rear end housing.
2. **CRANKSHAFT:** Stock stroke, Cast Eagle or Scat cranks ok (No stroker cranks)
3. **RODS:** Must be stock appearing rods
4. **PISTONS:** Flat-top pistons only (no Dome pistons) .060 max. bore.
5. **HEADS:** Cast iron heads only (No vortex, 305, double hump or closed chamber heads. Casting # (39863336), (333882), (462624), 3932441), (3973487), (3998993), (3973493), (932441) 1.940 intake valves, 1.500 exhaust valves on all heads Chevy, Ford, Dodge. No grinding or porting on heads. **NO** matching intake.
6. **INTAKE** Typhoon or Edelbrock 7101 Performer RPM. **NO** matching, grinding or porting on intake.
7. **ROCKER ARMS:** Roller Rocker arm allowed. 1.5 on Chevy; 1.6 on Ford. Numbers must be on Rocker Arms.
8. **CAMSHAFT:** Hydraulic cam only. (**NO** roller Cams) 490 lift max. with .010 tolerance.
9. **CARBURETOR:** 350 2 barrel stock, choke may be removed. Must check with gauges at any time before or after race. 1" adaptor only.
10. **DISTRIBUTOR:** HEI stock type or MSD OK to run.
11. **HEADERS** may be run.

### SUSPENSION and DRIVE TRAIN

1. Stock type ball joints.
2. **SHOCKS:** Steel shocks only. **Fix Bearing type SHOCKS** or (WB Series) or (FB Series) type only.  
**Buy rule on shocks.** May buy front shocks \$160 or rear shocks \$160. (Front and rear \$320)
3. **DRIVE SHAFT:** Steel only
4. **FRAME HEIGHT:** 4" at lowest point (Except cross members)
5. **REAR END:** 9" Ford allowed, Floaters allowed. Mini-spool or full spool only. (No quick changes) **NO** Lockers

6. **TRANSMISSION:** 3 or 4 speed only, no racing transmission (like Tex, Jerico, Bert, Falcon, Brinnn)
7. **FUEL CELL:** Must be at least 8" from ground and have at least 2 1" straps around it.
8. **CLUTCH:** 7 1/4", 2 or 3 disc type clutches allowed only.

### **WHEELS, BRAKES AND TIRES**

1. 8" Steel Wheels only
2. Tires: Track Tires

Tires must be purchased from Sayre Speedway dealer and must have Sayre seal stamped on tire.

**SOAK RULE NO** Soaking or altering of tire in any manner allowed. Drivers soaking or altering tires will forfeit all purse and points for event and all points for year. Driver must also pay a \$1,000 fine prior to racing again. Any illegal tire (decision by track official) will be confiscated.

NO two way radios

### **PROTEST**

All protest must be handled in an orderly manner. Top end protest \$200.00. This checks for flat-top pistons, bore, stroke, ported heads, size of valves and cam lift. To pull intake is \$100.00. This checks cam lift and ported and polished heads. \$50 to pull inspection plug and see crank Numbers and rods. Drivers that can run this division will be at track discretion.

### **WEIGHT RULE**

1. 2500 lbs after race with driver.
- 2.. Weight may be added for minor infractions

**IF THESE RULES DO NOT STATE YOU CAN DO IT, YOU CANNOT.**

This division is based on keeping this class inexpensive like the Street Stock. Remember - Keep it cheap.

## LIMITED MODIFIED BODY DIMENSIONS FOR 2019

- A. 20" max 16" min. (ground to center of bumpers, front and rear)
- B. 6.5 min. (center to center)
- C. 52" max. 42" min.
- D. Hood 4" max. drop (sides). sealed off from driver's compartment and max. 3" rake.
- E. 42" max.
- F. 6" max.
- G. 4" min.
- H. 19" max., must be same on both sides.
- I. 112" max. 105" min.
- J. 27" max 22" min.
- K. 72" max. or not past back of block, right side. Left side may extend forward to cover foot box
- L. 18" max. 12" min. opening, both sides.
- M. With level, must have between 1/2" and 2" clearance at rear of roof, 1/2" to 5" at front.
- N. 120" max. 106" min.
- O. 48" max. 34" min.
- P. 5" Spoiler
- Q. Interior slope is 6" max. front to rear and flat across. If flat at front half of interior you have used up 50 % of your 6" so from behind driver to rear you may only have 3". Top of interior must be flush with top of door and quarter panels. An optional escape hatch from driver to passenger door to provide 12" opening allowed.
- R. 38" max 28" min.
- S. Max. no wider than front frame horns. Min. 24"
- T. 66" max. 24" min. no narrower than radiator.
- U. 52" max 44" min.
- V. 56" max. 41" min.
- W. Tires must be widest part of car.
- X. 66" max. 53" min.
- Y. All rear bumpers must be constructed of square or round tubing, no wider than five inches outside of rear frame rails and similar to drawing. If rear bumper is wider than five inches outside rear frame rails, it must be constructed in a loop design like drawing

Shaded area reserved for sponsor decals. MUST DISPLAY ALL DECALS TO BE ELIGIBLE FOR ANY CONTINGENCY AWARDS OR POINT FUNDS.

(P) 5" Spoiler

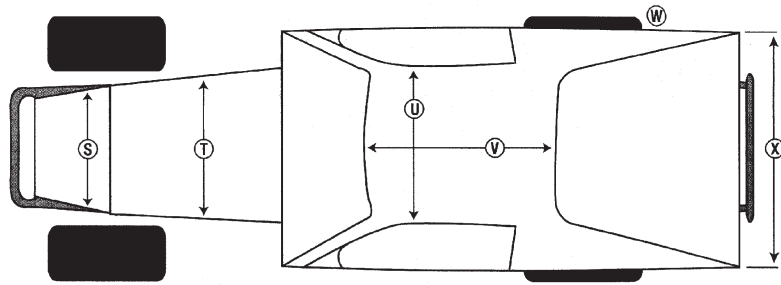
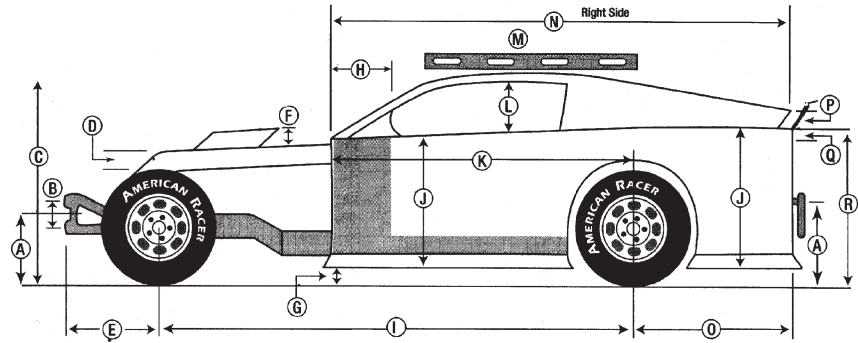

Sail Panels

Sail Panel

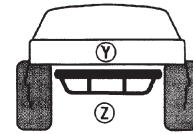
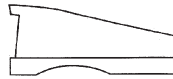

Rear Bumper

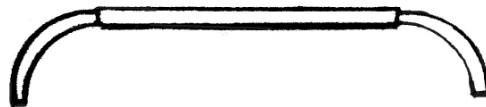

# 2019 SPORTSMAN

**THE INTENT AND INTERPRETATION OF THE RULES WILL BE THE DECISION OF OFFICIALS IN CHARGE. IT IS STRONGLY RECOMMENDED THAT ANY COMPETITOR THAT HAS ANY QUESTIONS OR DOUBT ABOUT THE INTERPRETATION OR INTENT OF THE RULES CHECK WITH SPEEDWAY OFFICIALS. ALL DECISIONS OF THE OFFICIAL IN CHARGE SHALL BE FINAL.**

## **GENERAL**

1. Anything not specified in rules must be stock, in original position, from original manufacturer.
2. American made cars 108" wheel base minimum.
3. Cars must weigh minimum 2950 lbs. with driver. 57% left side weight.
4. Weight may be added for infraction of rules to make competition equal.
5. **NO** 2 way radios.

## **ENGINE AND DRIVE TRAIN**

1. Must be factory stock for make of car. Stock stroke. Max. .060 bore.
2. Flat top or dish pistons. Solid or hydraulic flat tappet cam only. No roller cams. May run roller rocker arms.
3. Stock cast iron heads as available from manufacturer. (**NO** porting or polishing.) Chevys may run Aluminum intake. **NO** porting or polishing intake. May run aftermarket heads and Angle plug heads with 50 lb penalty. Headers may be run. Ford & Chrysler may run aluminum intake.
4. Carburetors must be 500 cfm #4412. 1-11/16 throttle bore. Max. 1" adaptor.
5. Battery can be located in drivers compartment if covered.
6. **May run 7 1/4 disc type clutch**
7. **9" Ford Floater rear end may be run**
8. **Must be self-starting. NO electric fuel pumps**
9. **Headers may be run**

## **SUSPENSION**

1. Front spindle/axle/ball joint assemblies may be reinforced, or heavier duty unit from another passenger car installed. **NO** aftermarket spindles
2. Must have stock frame. Frame may be reinforced. **NO** notching or alteration to frame. Suspension type and location must remain stock.
3. **May run** wedge bolts. Shocks may be relocated on front and rear.
4. Uni-body frame sections may be connected as part of roll cage construction. A-frames must be stock, may run tubular upper A Frames. Stock Lower A Frame.
5. **SHOCKS No adjustable or Shrader Valve Shocks allowed. Steel shocks only  
NO Bump Stops**
6. **NO** frame lower than 5" from the ground.

## **BODY AND APPEARANCE**

1. Late Model type bodies allowed - 50 lb penalty
2. Outlaw Late Model bodies allowed - 50 lb. penalty
3. May run stock steel Monte Carlo type roof with no penalty
4. Body no lower than 5" from ground
5. Car must be safe in all ways possible. (See General Rules)

## **WHEELS, BRAKES AND TIRES**

1. Steel wheels - 8".
2. Disc Brakes may be run.
3. **TIRES:** Track Tires. Tires must be purchased from Sayre Speedway Dealer and must have Sayre seal stamped on tire.

**SOAK RULE NO** Soaking or altering of tire in any manner allowed. Drivers soaking or altering tires will forfeit all purse and points for event and all points for year. Driver must also pay a \$1,000 fine prior to racing again. Any illegal tire (decision by track official) will be confiscated.

Starting weight - 2950 lbs

<b>PENALTYS</b>	
After Market body or Late model or Outlaw	50 lb
Motors over 360 cu. in.	50 lb.
Roller Cams	25 lb
After Market Heads	50 lb
Fire wall & Floor pan not stock	50 lb

### **STOCK SNOOT CARS**

after market body and fabricated firewall 5" springs  
9" Ford floater rear end 56% left side weight.  
FB and WB type shock only.  
weight 3150 lbs.  
outlaw body no penalty  
aftermarket head no penalty

**PROTEST RULE** Protest must be handled as stated in General Rules.

1. **\$150 to see top end of motor - (that means anything that can be seen from top) bore, stroke, camshaft, head porting, no ported intakes or matching gas-kets. \$50 to check for roller cam. This will be done by pulling the distributor.**

**THE WINNER FROM LAST RACE WILL START NO BETTER THAN 9TH PLACE.**

## 2019 MINI MODIFIED

**THE INTENT AND INTERPRETATION OF THE RULES WILL BE THE DECISION OF OFFICIALS IN CHARGE. IT IS STRONGLY RECOMMENDED THAT ANY COMPETITOR THAT HAS ANY QUESTIONS OR DOUBT ABOUT THE INTERPRETATION OR INTENT OF THE RULES CHECK WITH SPEEDWAY OFFICIALS. ALL DECISIONS OF THE OFFICIAL IN CHARGE SHALL BE FINAL.**

### CARS LEGAL FOR DIVISION

Any 4 cylinder, 2 or 4 door (4 passenger) sedan, or station wagon foreign or domestic - between 90" and 105" wheel base.

**FUEL CELL** - Fuel cell **REQUIRED**. Must be mounted securely with 10" (ten inch) ground clearance. **ALL CARS** will have a fire wall between driver and fuel cell.

### ENGINE AND DRIVE TRAIN

1. Engine must be factory stock for make and model of car in stock position.
2. 2000 lb. minimum after race. Mustang with stock appearing body must weigh 2150 lbs. Mini Modified type cars with coil over type shocks and fiber glass bodies will have to weigh 2250 lb.
4. Engine can be balanced.
5. May run after market rods
6. No lightening or knife edging cranks (can be balanced). Stock stroke.
7. Anything can be done to the head. May be ported and polished and run any valve size. Fords may run aluminum head.
8. Any aluminum intake with maximum of 2" from intake to carburetor.
9. May run roller cam and rockers on Fords
10. Exhaust headers optional.
11. May run single or double disc type clutches such as 10,000 RPM or Goldstar, or Tilton with Aluminum Flywheel.
12. Stock transmission and rear ends. (Locked rear ends optional)
13. Carburetor stock 350 CFM (7448) Holley Carburetor. Must fit gauges. May remove choke plate. **No** cold air boxes.
14. Battery can be located behind driver but must be covered if run there. Must be self starting.

### BODY AND APPEARANCE

1. Bodies may be fiberglass or Aluminum



May cut holes in hood for air cleaners. Must check with official before running.  
Stock, firewall and floor pan (front and rear).

2. Stock size windshield. Side windows no more than 12 inches back on each side.
3. Safe steering shaft.
4. Dash may be made with steel or aluminum. Must reach from one side to other side.
5. Car must be safe in all ways possible. (See General Rules)
6. Car must have neat appearance
7. Spoiler - 5" spoiler

### **WHEEL, TIRES, BRAKES AND SUSPENSION**

1. Steel wheels. 8"
2. **TIRE RULE:** Track tires

Tires must be purchased from Sayre Speedway dealer and must have Sayre seal stamped on tire

**SOAK RULE NO** Soaking or altering of tire in any manner allowed. Drivers soaking or altering tires will forfeit all purse and points for event and all points for year. Driver must also pay a \$1,000 fine prior to racing again. Any illegal tire (decision by track official) will be confiscated.

3. Stock brakes. Can run adjustable brake pedals
4. Stock suspension required in stock position - may be reinforced. A-frames can be shortened or lengthened to set front-end. May run Jack Bolts in rear.
5. Weight may be added for minor infractions
6. Heim joints legal on suspension

### **CLAIM & PROTEST**

All protest will be handled in an orderly manner. Refer to General Rules. You have 10 minutes to protest after the race.

NO Two way radios

**THE WINNER FROM THE LAST RACE WILL START NO BETTER THAN 9TH PLACE**

**Buzz cars with fuel injection may move up to mini modified if needed. Weight starts at 2300 lbs with mini modified tires**

## 2019 HOGGS

**THE INTENT AND INTERPRETATION OF THE RULES WILL BE THE DECISION OF OFFICIALS IN CHARGE. IT IS STRONGLY RECOMMENDED THAT ANY COMPETITOR THAT HAS ANY QUESTIONS OR DOUBT ABOUT THE INTERPRETATION OR INTENT OF THE RULES CHECK WITH SPEEDWAY OFFICIALS. ALL DECISIONS OF THE OFFICIAL IN CHARGE SHALL BE FINAL.**

**DRIVERS** - Drivers that can run this division will be at track discretion.

It has come to our attention that some are using metal battery boxes as ballast. This will not be allowed. If you are moving your battery to the inside of your car, you can use an RV battery box. This must be covered with plastic lid. Must be secured to the floor and be secured by a 1 inch washer with lock nuts. You may use U bolt to secure or you may use a metal strap across the top to secure. Remember this is for your protection - fasten this securely or you will not be allowed to race. If you are leaving the battery under the hood, you do not have to have a battery box.

Must be 1972 or newer model passenger car body

### HEADS

1972-1987 passenger car heads

No fuel injected heads. Stock or stock replacement carburetor. GM cars quadrajet or 2 barrell Rochester. Ford 600 or stock.

Stock valves for number on heads. Max 185 for 305, Max 194 for 350

Heads must have been available on 1972-1987 passenger cars.

NO stud girdles, NO rollers

4 angle valve job with last cut being a max of 75 degrees out.

This does not give you the approval to abuse this, there will be no bowl hogging or no gasket matching.

Remember no heads that were for bus or truck only.

## MOTORS

**NO** high performance Engines

Max allowable compression is 180 pounds for 305, and 165 pounds for 350.

Heads must match motor.

Minimum 20 inches of vacuum at 1000 rpms or subject to tear down.

(**NO** Hydraulic rollers) **NO** Rhodes or anti-pump up lifters

Moroso stock type steel motor mounts optional

Pulleys stock only

To make easier to understand you can pad balance, you can crank balance, use a harmonic balancer or a fluid damper.

Double roller timing chains ok

Stock replacement rods ok STD. May use Powder rods

Length STD.

Weight STD.

After market rod bolts ok.

Claimer pan ok.

Poly locks ok

May run cast or forged pistons, must be stock weight

## CAMS

Cam buttons optional

**NO** cam bushings - must run straight up as drilled from factory

Cams CCS-2 or CS274 only

## BODY AND FRAME

104 to 111 3/4 wheel base 305 max based on manufacture measurements

112 or greater 350 Chevy, 351 Ford, 360 Chrys max.

Minimum 7" frame and body height

Stock springs on all corners, no shims, **NO** jack bolts, **NO** wedges, and **NO** enhancements at all

Must have minimum 4 point cage connected to frame. Must have Halo bar.

May have door bars.

Door hinges, locks, and side impact bar must remain in door.

Doors must be securely fastened shut.

**NO** gutting. Hood optional stock appearing. May remove all A/C components  
May remove plastic dash - cover with sheet metal  
Battery must be tied down and covered, including dry cell.  
Must remove all glass. If using glass windshield, must wear goggles or face shield.  
May use screen or lexan.  
May remove back seat, carpet, headliner, and trim panels.  
RACING SEAT required. 5 point seat belt required.  
Stock gas tank or fuel cell. Fuel cell must be centered between frame rails.  
Bottom of cell no lower than bottom of frame.  
May use sheet metal or aluminum for door skins or fender skins. Must be fabricated to look like original. This includes  
Stock height, Stock length, Stock weight of vehicles. If ballast has to be added it will be added to the center of the car. Call TECH for information before you do this.  
**DO NOT ABUSE THIS RULE.**  
May cut shim on front sway bar by **2" ONLY.**

### **TRANSMISSION**

AUTOMATIC ONLY. **NO** power glides

### **SUSPENSION**

Stock suspension **ONLY.** **NO** modifications  
**NO** racing shocks (If it can be identified as a racing shock then it is illegal)

### **REAR ENDS**

Rear ends and gears stock only. **NO** limited slip or locked.  
You cannot shim or otherwise lock rear ends in any fashion. You cannot fix it with any device to where your rear end will lock. This will result in a **DQ.**

### **TIRES and RIMS**

Any size between 175-235. 65, 70 or 75 DOT Street tires 14" or 15" 3 1/2 offset only.  
May run racing wheels. 7" wheels  
Wheels other than 14" or 15" must be BASE model size tire and wheel for later model cars. V-6 and V-8.  
V-6 cars may run with fuel injection on BASE model wheels and tires. **NO** sport V-6 cars.

## 2019 LATE MODEL

**THE INTENT AND INTERPRETATION OF THE RULES WILL BE THE DECISION OF OFFICIALS IN CHARGE. IT IS STRONGLY RECOMMENDED THAT ANY COMPETITOR THAT HAS ANY QUESTIONS OR DOUBT ABOUT THE INTERPRETATION OR INTENT OF THE RULES CHECK WITH SPEEDWAY OFFICIALS. ALL DECISIONS OF THE OFFICIAL IN CHARGE SHALL BE FINAL.**

### CHASSIS

Tubular Frame cars w/coilovers

Built Motor Cars and 604 Crate Cars

602 Crate Motor

2750

2600

**LEFT  
SIDE WEIGHT**

58%

59%

### ENGINE RULE

Cast iron blocks only.

Engine compression cubic inch not limited

One Carburetor (any size)

### CLUTCH AND TRANSMISSION

Must have forward and reverse gears

### WHEELS, TIRES

10" Steel wheels only (any offset)

Track Tires- Tires must be purchased from Sayre Speedway dealer and must have Sayre seal stamped on tire

### SHOCKS AND SPRINGS

Any Shock and Springs

Bump Stops OK

### FUEL CELL

Fuel cell mandatory. 8" minimum ground clearance. Must have 2 straps across top of cell to protect cell.

### BODY

Any late model bodies or outlaw type bodies no wider than 82".

### SPOILER

6" Spoiler

Two way radios will be allowed for safety reasons. Track reserves the right to take away from any driver using them for wrong reason.

If you have questions call Bary Martin (205) 674-0367  
For Race Car Numbers, call Sandra Parker (205) 798-2171

